

Agrimag

Series

User Guide

Agrimag

AgrimagP and AgrimagP2



Battery Powered



Externally Powered



Aquamonix Pty Ltd

92 Furniss Road
Landsdale 6065
Western Australia

phone +61 8 9477 1188

www.aquamonix.com.au

List of Contents

1. Introduction	3
1.1. Operating Principle	3
1.2. Applications	3
1.3. Safety Instructions	3
1.4. Unpacking the flowmeter	3
2. Installation	4
2.1. Sensor Installation	4
2.2. Position of flowmeter	5
2.3. Connections	6
3. Agrimag, AgrimagP, AgrimagP2 Unit	7
3.1. Main screen	7
3.2. Errors and Warnings	8
4. Power Supply	9
4.1. Agrimag Battery Specification	9
4.2. Agrimag - Battery life	9
4.3. Agrimag - Changing the battery	9
4.4. Agrimag - Battery conservation	9
4.5. AgrimagP – Power Supply	10
4.6. AgrimagP2 – Power Supply	10
5. Outputs	11
5.1. AgrimagP – Frequency output	11
5.2. AgrimagP2 – Current loop output	11
5.3. AgrimagP2 – RS485	12
6. Internal backup	13
6.1. Automatic data saving	13
7. AgrimagP2 connection to PC	13
8. AgrimagP2 - Datalogger	13
9. AgrimagP2 SW	14
9.1. System requirements	14
9.2. Installation/Uninstall AgrimagP2 software	14
9.3. Service section	15
9.4. Statistic section	16
10. Cleaning	17
11. Specifications	18
12. Flowmeter dimensions	19
13. Fittings	20
14. Troubleshooting	22
14.1. Trouble: non working display	22
14.2. Trouble: Non stable flow or Empty pipe alarm	23
14.3. Trouble: Error overloaded	24
14.4. Trouble: Error excitation	25
14.5. Trouble: AD – converter error	25
14.6. Trouble: Low battery error*	26
15. How to order your Agrimag, AgrimagP, AgrimagP2	26
16. Appendix	27
16.1. CE requirements	27
16.2. Warranty	27
16.3. Contact	27

1. Introduction

1.1. Operating Principle

The measurement is based on the principle of Faraday's law of electromagnetic induction where a voltage is induced in an electrically conductive body that moves in a magnetic field. Liquid flows through a tube in the direction of the magnetic field. Liquid with a certain minimum electrical conductivity induces a voltage which is detected by two electrodes located in a 90 degree angle from the magnetic field and the flow direction.

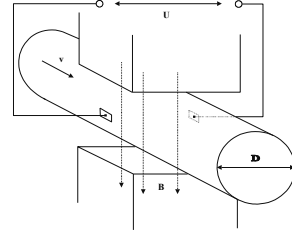

Minimum liquid conductivity	$\geq 20 \mu\text{s} / \text{cm}$
Liquid velocity	min. 0.1 m / sec, max. 10 m / sec.

1.2. Applications

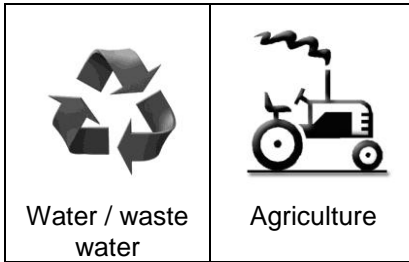

1.3. Safety Instructions

	Please read this manual carefully before using the product.
--	---

	Keep this manual for future reference. Aquamonix Pty Ltd will not be liable for any damage caused by improper use of the product or its accessories.
--	--

	The Agrimag, AgrimagP, AgrimagP2 flowmeter must not be mounted in explosive hazardous areas.
--	--

1.4. Unpacking the flowmeter

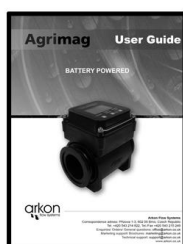

- ❶ When unpacking the flowmeter, conduct a visual check of the flowmeter upon receipt to make sure the product has not been damaged during transport.
- ❷ Check the completeness of the package. In case of any problem, contact the Arkon sales department without delay.
 - Flowmeter
 - Manual
 - AgrimagP, AgrimagP2: cable

2. Installation

2.1. Sensor Installation

Proper installation is extremely important in order for your flowmeter to work correctly. There are minimum sensor installation requirements that need to be respected at all Times. Please note that Arkon cannot warranty any installation which does not comply with these requirements.

Horizontal standard mounting

The sensor tube must always remain full. The best way to achieve this is to locate the sensor in a low section pipe, see the following picture.

It is mandatory to install the sensor in a section of straight pipe with at least 5 times the pipe diameter before sensor and 3 times after sensor.

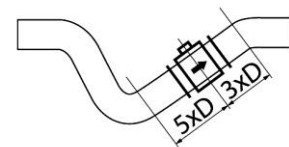
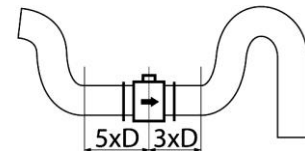

Pipe reducers

If the pipe diameter is not the same as the diameter of sensor, then pipe reducers can be used. So as not to lose accuracy of the measurement, the slope of reducers should not exceed 8° .

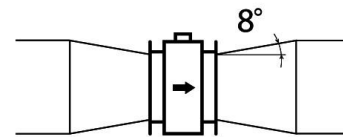

Vertical mounting

When the sensor is mounted on a vertical section of pipe, the flow direction must be upwards. In the case of a downward flow direction, air bubbles can collect in the sensor and the measurement could be unstable and inaccurate.

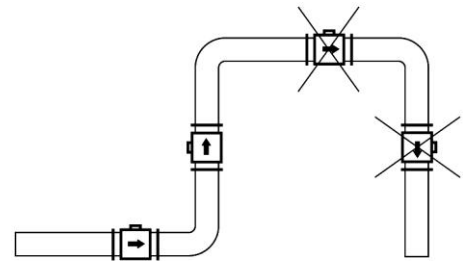

Pumps

Never install the sensor on the suction side of a pump or on a section of pipe where a vacuum is possible.

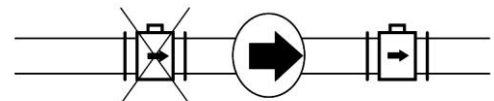

Valves

Suitable location of a shutoff valve is downstream of a sensor.

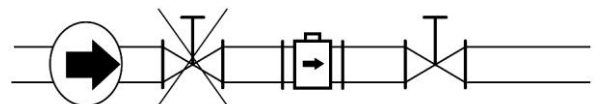

The sensor head has to be properly tightened

During the sensor installation please check the head and the four screws for proper tight.

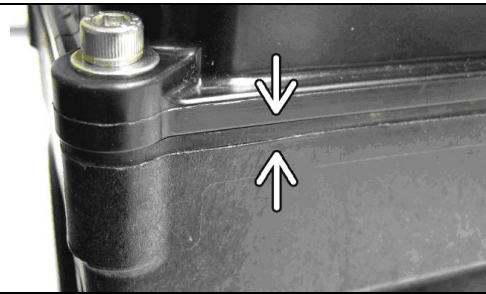

Removal during maintenance

If the application requires removal of the sensor for periodic maintenance, it is recommended to install a bypass section as the drawing below.

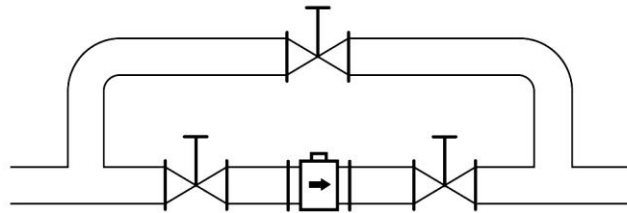

2.2. Position of flowmeter

This is an all position flowmeter which can be installed either vertically or horizontally, register up, down or angled. However, entrained air or solids may make some positions preferable to others. See the position diagram for guidance. The correct position will be related to the function of the electrodes. The two electrodes located on the vertical axis of the flowmeter are used for earthing purposes. The two electrodes located on the horizontal axis of the flowmeters are used for measuring.

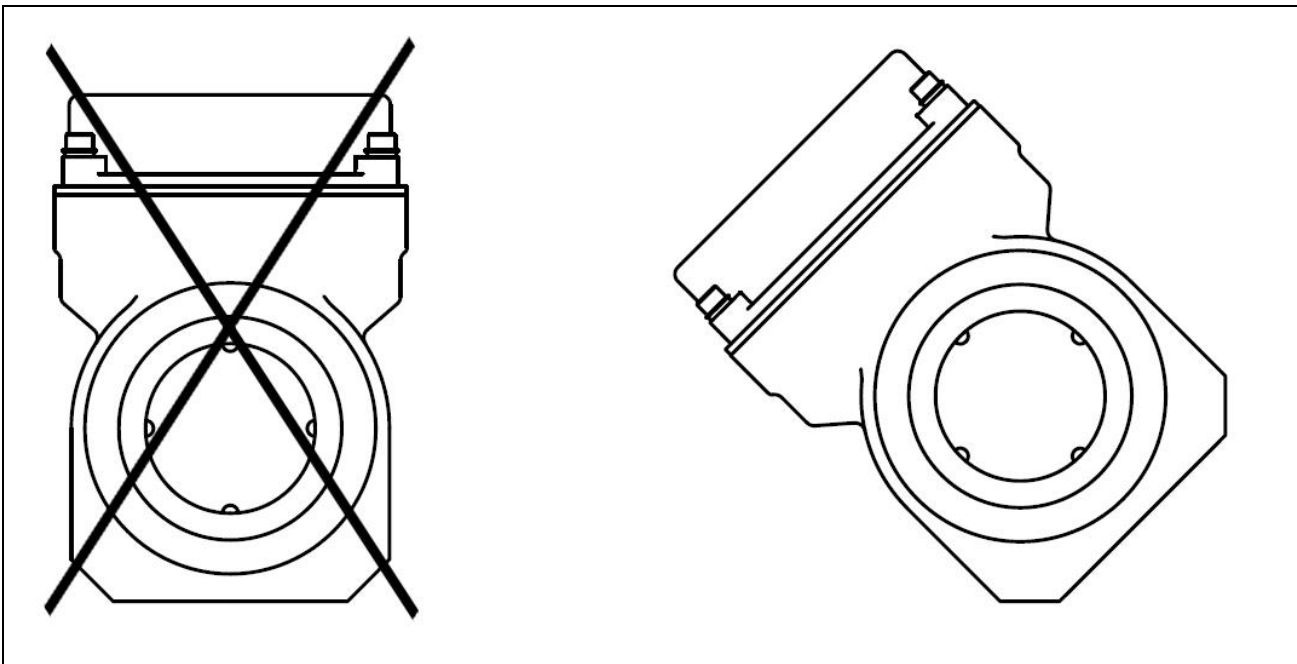



In this position, if there are any air bubbles or if sediments accumulate in the lower part of the flowmeter, it will could have an adverse effect on the earthing, which could influence the accuracy of the measurement.

By rotating the flowmeter, it is possible to prevent the sediments accumulating at the earthing electrodes. Also there is less chance of the air bubbles affecting the earthing electrode.

2.3. Connections

Follow the diagram below to make the connections:

	<p>Step 1 Position gasket at either end</p>
	<p>Step 2 Place adapter against gasket, open screw clamps to clear flanges</p>
	<p>Step 3 Place screw clamps over both adapter and meter flanges and tighten screws</p>

3. Agrimag, AgrimagP, AgrimagP2 Unit

The Agrimag, AgrimagP, AgrimagP2 flowmeter consists of the motherboard, a graphical display, touch-buttons and sensor housing. Through the display and with help of the controls, you can see and change flow and totalizers.

The following symbols are used in this manual and on the flowmeter display.

3.1. Main screen

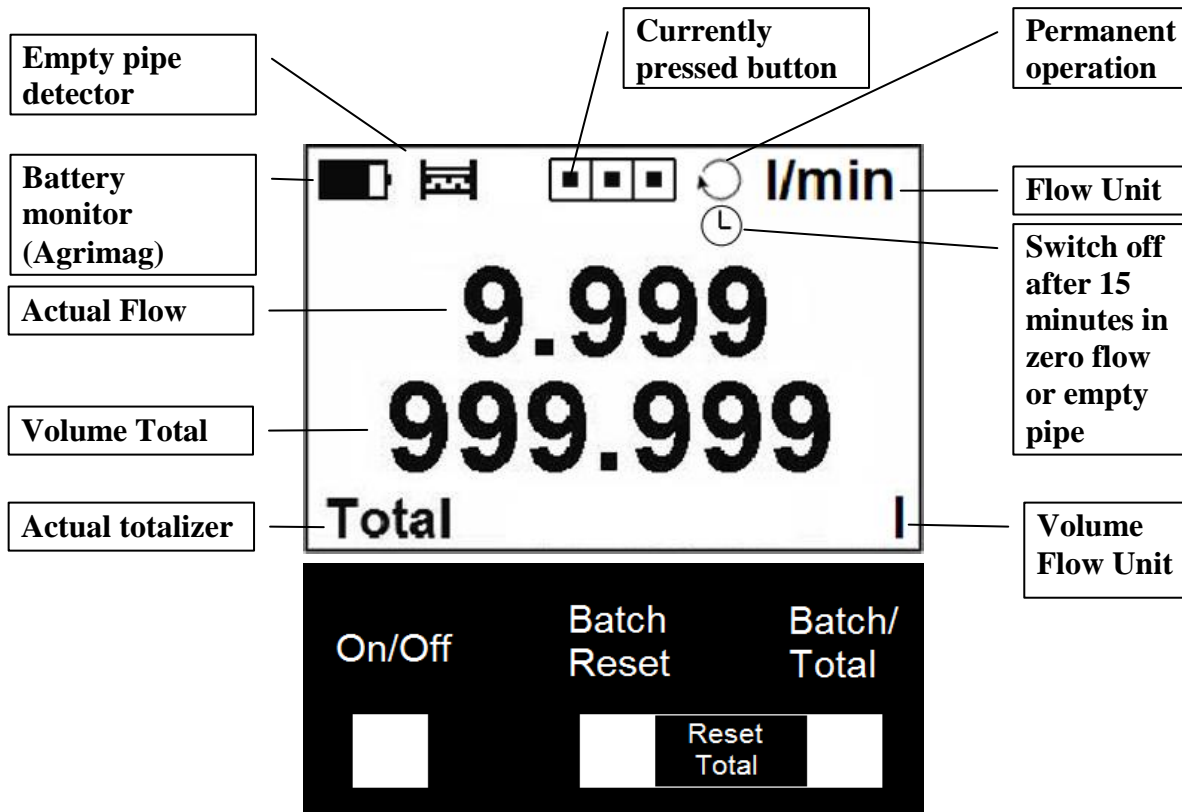

Note: these are not pushing buttons, to activate hold your finger over the white rectangle for 2 to 4 seconds.

On/Off

Turns the meter on, switching the meter off.

Batch Reset

Clears the Batch volume.

Batch/Total

Switches between totalizers.

Combination Batch Reset and Batch/Total together

Clears the Total volume.

Combination On/Off and Batch/Total together

Changes the unit of a system (l/s and USG/min, resp. litres and gallons, etc.)

Combination On/Off and Batch Reset together

Changes permanent operation and Battery saving mode.

Total Volume

This is the total volume counter. Negative flow is not counted.*

Batch Volume

This counter works the same way as Total Volume. Both counters are independently clearable.*

*If value of any Volume counter higher than 4 000 000 m³, than value of Volume show only in m³ unit. If value of any Volume counter higher than 999 999 999 m³, then this Volume will be reset to 0

3.2. Errors and Warnings

That is a list of the possible errors for Agrimag/AgrimagP:

Low Battery status

If the Low Battery appears on the screen, we recommend that the existing batteries are replaced with new batteries. Note: Applies for battery operated version only.

Empty Pipe

If the Empty pipe appears on the screen there is no medium in the pipes, the meter is preserving batteries until the pipes are full again.

Excitation

Coils interrupted or disconnected.

AD-converter

AD converter fault.

Note: The error disappears when the cause of it is fixed. You can see the measurement when you touch any of the controls.

Overloaded

That error occurs when the measured flow is bigger than $1.2 \cdot \text{Flow Qn}$. Depending on the size:

Size 25mm: 20.76m³/h

Size 50mm: 81.6m³/h

Size 80mm: 211.2m³/h

Generally that error will occur when the AD converter is overloaded. It can be because on the electrodes are very big voltage or because the flow is really that high.

4. Power Supply

The Agrimag series consists of three versions:
Agrimag – Battery powered meter
AgrimagP – External DC power powered meter
AgrimagP2 – External DC power powered meter

4.1. Agrimag Battery Specification

Electrical Specifications	
Size	6x AA size battery
Nominal voltage	1,2-1,6VDC
Operating time	Battery capacity dependent

4.2. Agrimag - Battery life

The battery life can be from 1 year to 3 years depending on measuring or sleeping mode.
The battery operation time depends on ambient temperature, conditions, flowrate profile etc.

4.3. Agrimag - Changing the battery

- 1- Unscrew 4x IMBUS 4 screws.
- 2- Carefully open the display part of the flowmeter.
- 3- Open battery holder and remove batteries.
- 4- Install new six pieces AA batteries 1,2-1,6V.
- 5- Close battery holder.
- 6- Close display part of the flowmeter, mind the cables.
- 7- Tight the 4x IMBUS 4 screws.



The display part has to lie on a sealing and body during simultaneous tightening of all four screws to avoid mechanical tension in display part! Risk of mechanical damage to display cover and leaking.

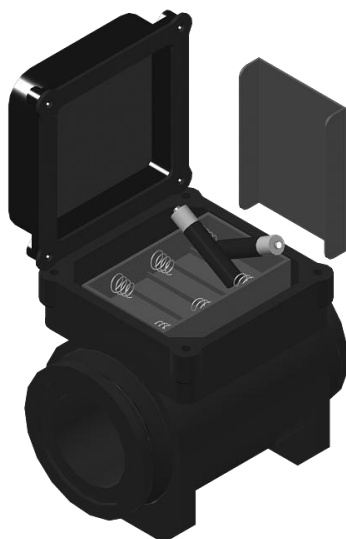

4.4. Agrimag - Battery conservation

Agrimag has **two working modes**: permanent operation mode and battery saving mode.

- Permanent operation mode: the meter continuously operates, regardless of flow rate.
- Battery saving mode: the meter switches off after 15 minutes with no flow or empty pipe, the user needs to switch it on again using On/Off button.

See 3.1 for information about setting the working mode.

4.5. AgrimagP – Power Supply

- The voltage power supply range is 9 – 35VDC.
- Maximum current consumption 20mA.
- Connection to the unit is done via CA6 connector – a part of the delivery – standard 1m.
- Maximum cable length is 20mts.
- The power supply input is protected against reverse polarity and voltage spikes.

Colour coding:

Brown ... +U

White GND

Green ... OPE

Yellow OPC



4.6. AgrimagP2 – Power Supply

- The voltage power supply range is 9 – 35VDC.
- Maximum current consumption 20mA.
- Connection to the unit is done via CA6 connector – a part of the delivery – standard 1m.
- Maximum cable length is 20mts.
- The power supply input is protected against reverse polarity and voltage spikes.

Colour coding:

Brown ... +U

White GND

Green ... A (RS485)

Yellow B (RS485)

Gray I/O (4-20mA)

Blue -V (4-20mA)

Pink +V (4-20mA)

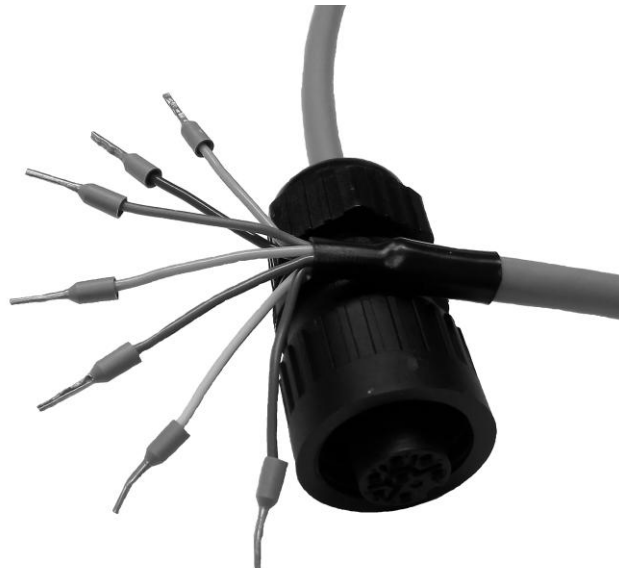

5. Outputs

5.1. AgrimagP – Frequency output

Each AgrimagP is equipped with 0-1000Hz frequency output proportional to actual flow.
 Standard open collector circuit.
 Max switching voltage 24VDC, max current 50mA

A1": 211,765 pulses/lt
 A2": 52,941 pulses/lt
 A3": 20,455 pulses/lt

Colour coding:
 Brown ... +U
 White GND
 Green ... OPE
 Yellow OPC

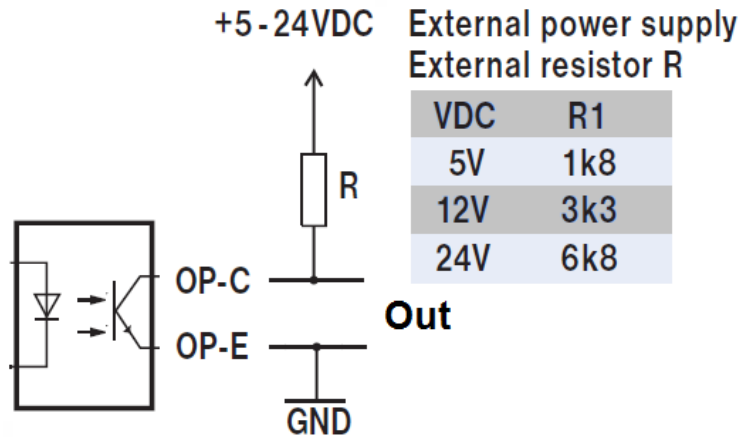

5.2. AgrimagP2 – Current loop output

Each AgrimagP2 is equipped with embedded 4-20mA current loop output signal module proportional to actual flow.

Electrical Specifications:	
12-bit DAC	
Maximum Resolution 3.9 μ A.	
Output mode	Active or Passive

Colour coding:
 Brown ... +U
 White GND
 Green ... A (RS485 communication bus)
 Yellow B (RS485 communication bus)
 Gray I/O (4-20mA)
 Blue -V (4-20mA)
 Pink +V (4-20mA)

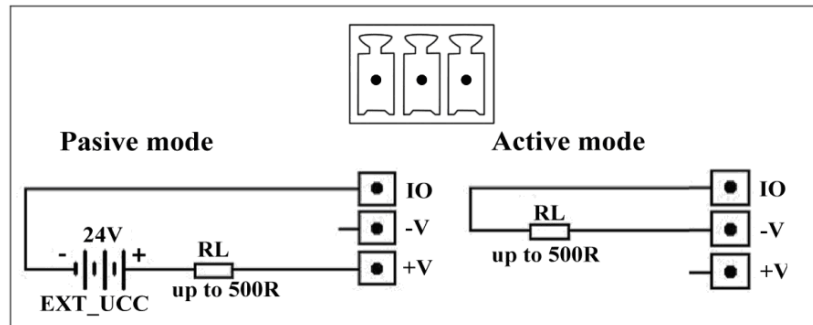

5.3. AgrimagP2 – RS485

Protocol	MODBUS RTU – for detailed information see AgrimagP2 MODBUS guide
SW	Standart Arkon SW
Baud rate	9600 baud/s

BASIC CIRCUIT CONNECTIONS:

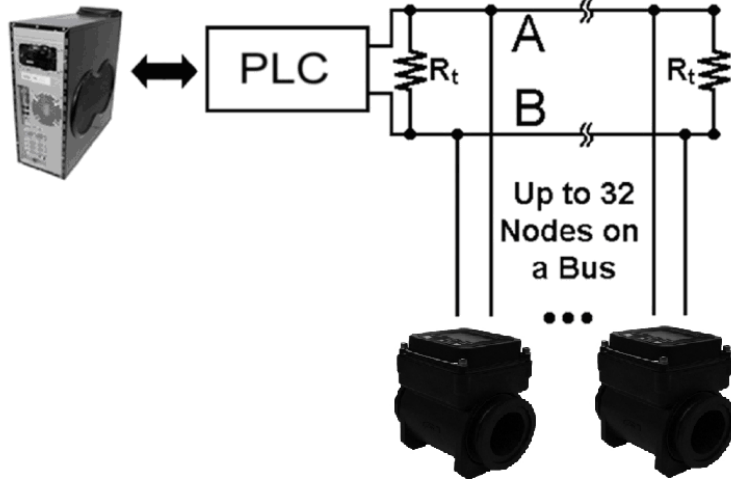

Multi-Node Network with End Termination using RS485

Terminator R_t with resistance 100Ω should be connect to the end of line RS-485.

Colour coding:

Brown ... +U

White GND

Green ... A (RS485 communication bus)

Yellow B (RS485 communication bus)

Gray I/O (4-20mA)

Blue -V (4-20mA)

Pink +V (4-20mA)

6. Internal backup

6.1. Automatic data saving

Once an hour some data is saved to the internal EEPROM. These are:

- Total
- Batch

When the batteries are removed, the last Total and last Batch will be saved in the EEPROM until the unit is switched on again.

7. AgrimagP2 connection to PC

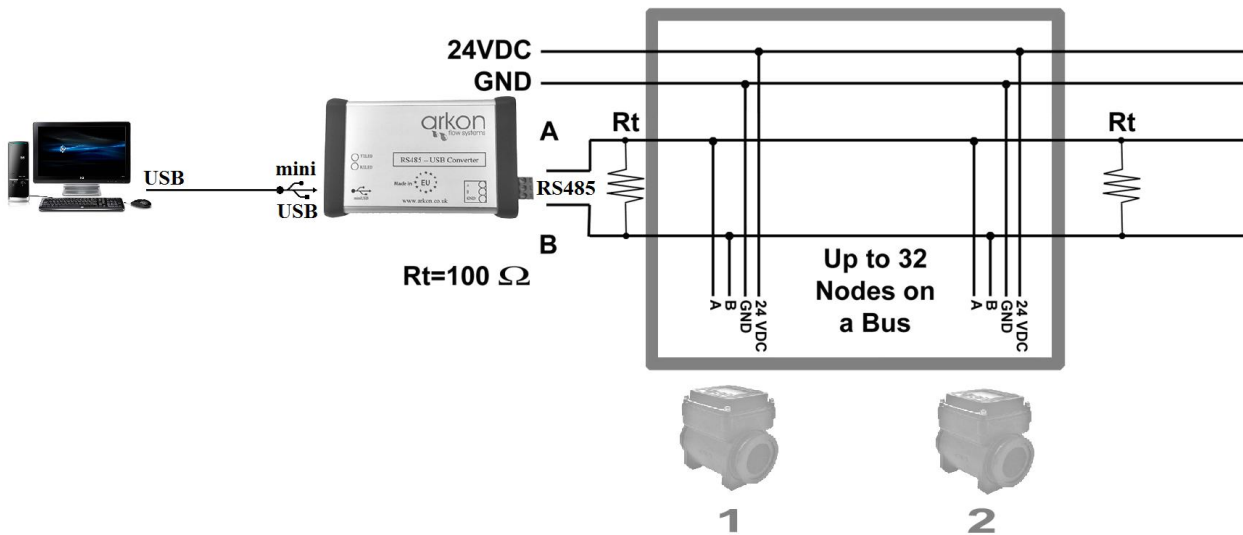

Picture above shows practical connection AgrimagP2 to PC through USB using RS485 – USB Converter.

8. AgrimagP2 - Datalogger

Data from datalogger save into external Flash memory. Capacity for write entries is 131072 (one entry has 8B)

All items in Datalogger are creating from 8 Bytes:

Date	Time	Total+
2B	2B	4B

For more information see AgrimagP2 Modbus User Guide.

9. AgrimagP2 SW

9.1. System requirements

There are minimum software requirements of your computer that must be satisfied to ensure that the software functions properly. These are:

MS Windows 98/ME/NT/2000/XP/Vista/Windows 7 operating system.
AgrimagP2 software program
RS485 input to your computer

9.2. Installation/Uninstall AgrimagP2 software

If you received the AgrimagP2 SW on a CD, place the CD-ROM with the AgrimagP2 software in your CD drive. Double-click on the CD-ROM symbol in the "My Computer" folder on the Windows desktop. Then run the "Setup.exe" in the "AgrimagP2 Software" folder.

The installation package can be downloaded from Arkon website.

To uninstall AgrimagP2 SW in „Settings“ (Start menu), under „Add/remove programs“ you select AgrimagP2 and then click the „uninstall“ button.

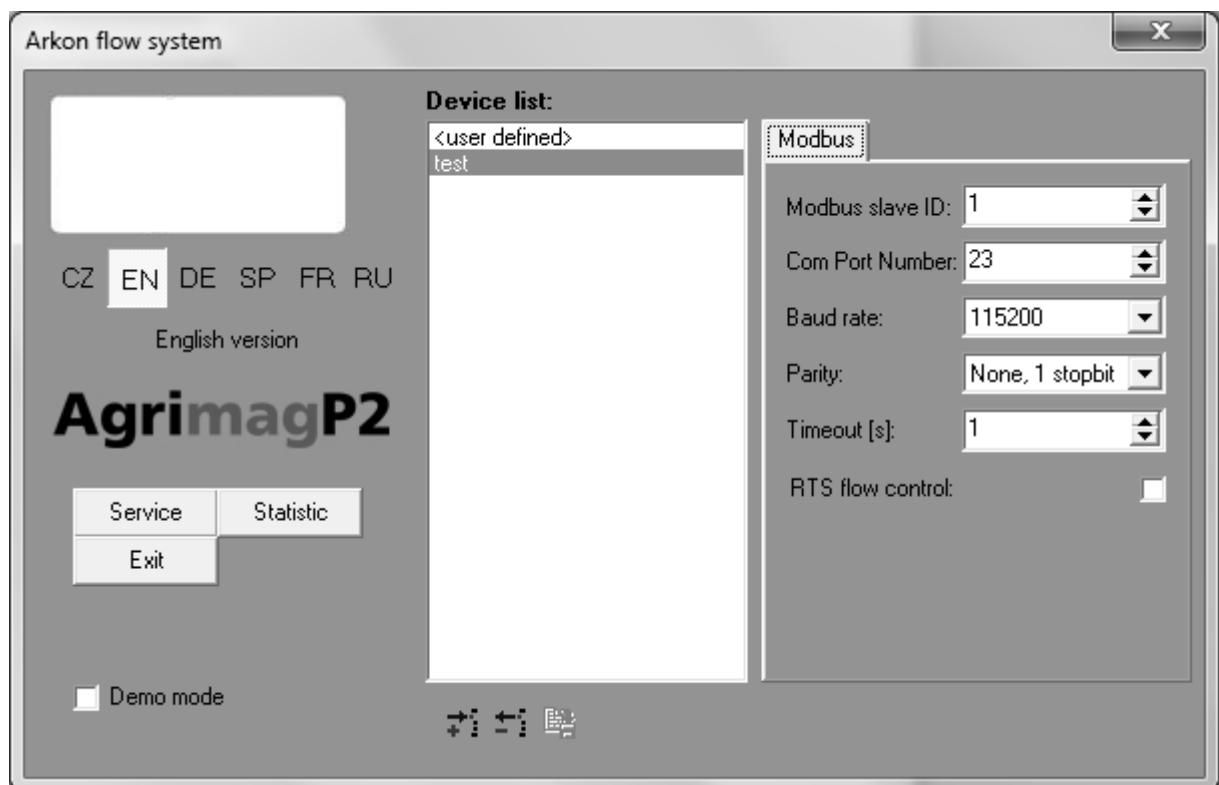

The AgrimagP2 software program consists of two independent sections:

- **The SERVICE section (“Service”)** – This section serves for overall remote configuration of the flowmeter. You enter this section by clicking "Service" in the above window.

- **The STATISTIC data-reading section (“Statistic”)** – This section serves for reading/exporting statistical data for given time periods from the flowmeter. You can enter this section by clicking “Statistic” in the above window.

The communication parameters needs to be set same in the device and in the SW

You can add shortcuts to your devices in Device list section by clicking on + sign below window.

9.3. Service section

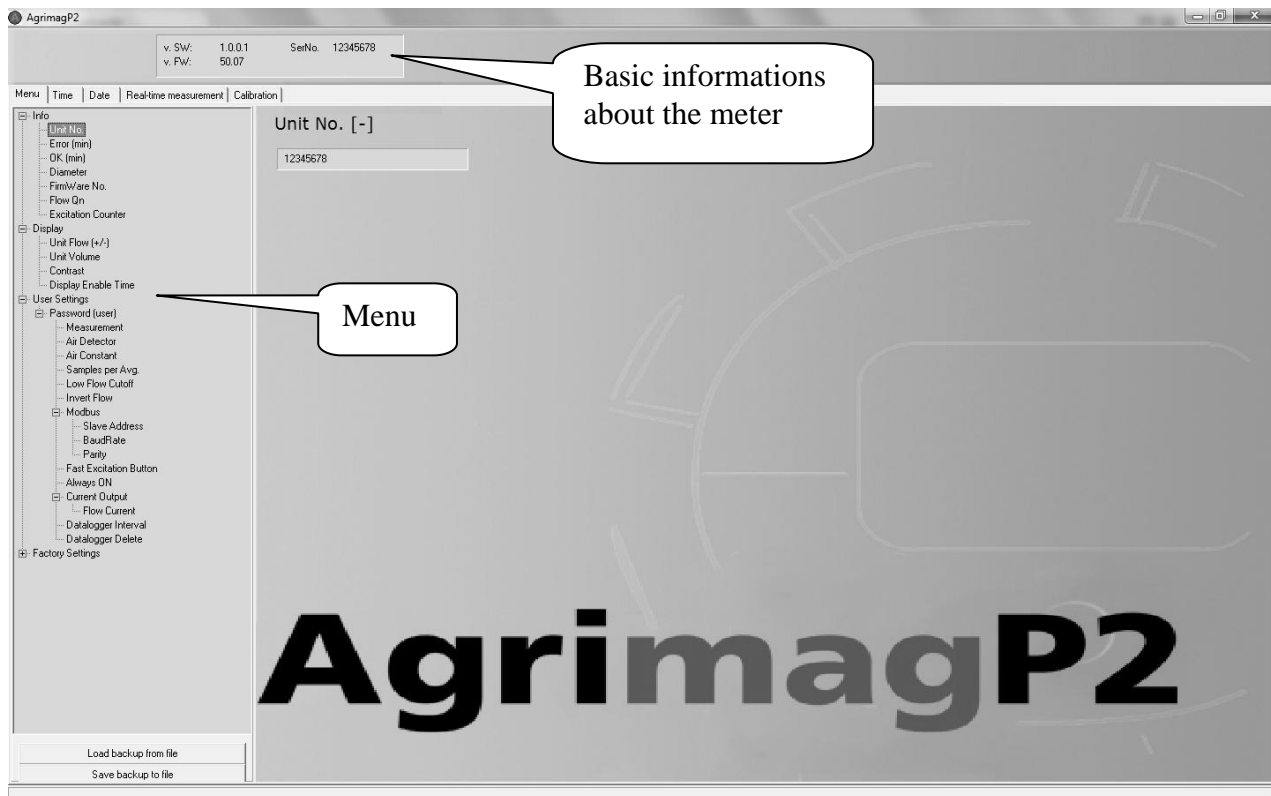

TABS

- **MENU** - The left-most tab is the "menu" tab, which will display the item selected in the menu-tree on the left hand side of the main window. Some items are only accessible after entering the correct password. When asked for a password, simply enter the correct password for the given section (User and Factory password) and click OK.
- **TIME** - The next tab is "Time". Here, you can enter the correct time.

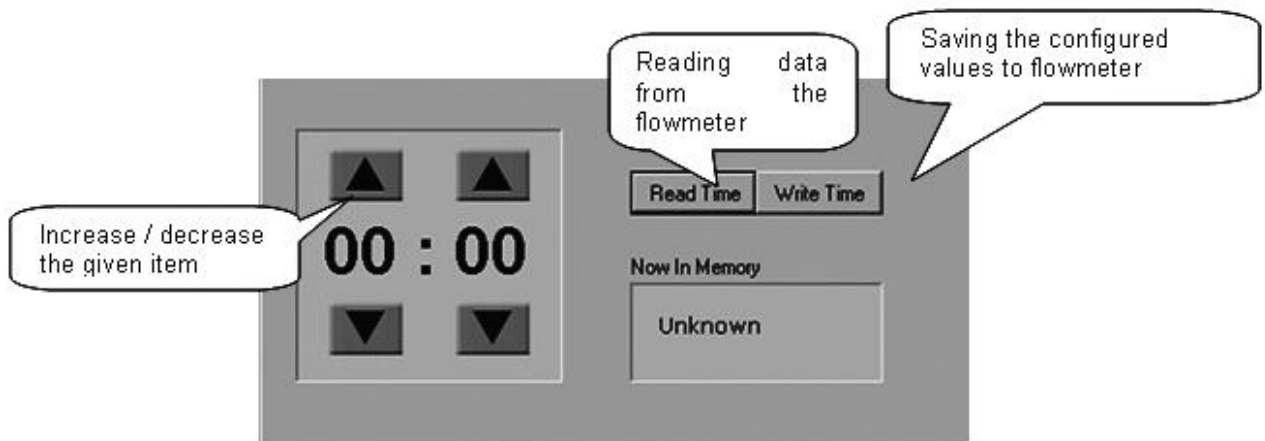

- **DATE** - The third tab from the left is "Date". Here, you can enter the correct date. (Settings are the same as *TIME* - Tabs)
- **REAL – TIME MEASUREMENT** - The 4th tab is "Real-time measurement" and it serves to view actual current flow. The current flow is shown as the first item on top of this window, but it is also depicted in the form of a graph at the bottom. This graph shows current flow data for the last 100 seconds of measurement. On right side are actual errors in red color.

The screenshot shows the main interface of the AgrimagP2 software. At the top, it displays version information: v. SW: 1.0.0.1, v. FW: 50.07, and SerNo: 12345678. Below this is a menu bar with options: Menu, Time, Date, Real-time measurement, and Calibration. The main area is divided into several sections:

- Flow Data:** Shows 'Flow: 20.000 m3/h', 'Total: 0.000 m3', and 'Batch: 0.000 m3'. There are dropdown menus for units (m3/h and m3) and a field for 'Error codes' containing a long string of zeros.
- Error table:** A table with the following content:

Empty Pipe	Overloaded	EEPROM Erase	EEPROM Write
Reserved	Excitation	ADC	Low battery
Flow > QMax	Reserved	Reserved	Reserved
Reserved	Reserved	Reserved	Reserved
- Graphical representation:** A line graph titled 'Actual Flow' showing flow rate over time. A callout points to it with the text 'Graphical representation of flow in time'. Another callout points to the flow data fields with the text 'Actual flow and totalizers data'.
- Actual Error:** A callout points to the error table with the text 'Actual Error – marked red'.

The large text 'AgrimagP2' is visible at the bottom of the interface.

9.4. Statistic section

The screenshot shows the 'AgrimagP2 - Statistic' window. It features a table with the following columns: Date, Time, and Total +. The table is currently empty. Below the table, there are three callouts pointing to buttons: 'Load data from AgrimagP2', 'Save data to .csv file', and 'Print the data'. At the bottom of the window, there is a progress bar showing 65% and a set of control buttons: Options..., Load, Export, and Print.

*.CSV file

This format file is standard output format for databases. Examples open in Microsoft Excel.

10. Cleaning

Agrimag, AgrimagP and AgrimagP2 electromagnetic flowmeters do not have any moving parts so special maintenance is not required, however we strongly recommend:

1. To check battery life at least once a year and change the 6 batteries if the meter shows “low battery status”
2. Do yearly mechanical cleaning of the sensor to remove any sedimentation from liner or electrodes. That is enough to rub the inside the tube with a piece of emery cloth

11. Specifications

Measurable media	Conductive fluids	
Min. Media electrical conductivity	≥20μS/cm	
Flow range	0,1 to 10 m/s	
Displayed values	Flow range (m3/h, l/s, l/m, US gal/min, UK gal/min), Volume (m3, l, US Gal, UK Gal)	
	Total, Batch volume	
Accuracy	±1% of reading from 100% to 10% of full scale ±3% of reading from 10% of full scale to cut-off	
Full scale	1": 0.5 – 4.8 l/s 2": 1.9 – 18.9 l/s 3": 5.0 – 49.0 l/s	
Power supply	Agrimag: 6 AA alkaline batteries, expected lifetime 1 year	AgrimagP, AgrimagP2: 9-35VDC Power supply available in special connector
Flow direction	Bi-directional measurement	
Ambient temperature	-12 to 54°C (10 to 130°F)	
Media temperature	0 to 60°C (32 to 140°F)	
Display	LCD 128 x 64 px graphical, sleep mode	
Control	3 touch buttons	
Low flow cut-off	2% of full scale	
Electronics protection	NEMA 4X standard	
Other features	Test of excitation coils Earthing through 3rd and 4th electrodes Empty pipe detection - battery conservation	
Excitation frequency	1/1,67s	
Samples per Average	4 excitations	
Coils resistance	100Ω	
Frequency output (AgrimagP)	Open collector proportional to flow 0-1000Hz for 0-Qmax Max switching voltage 24VDC, max. current 50mA	
Current loop output (AgrimagP2)	Max. current 24mA	
Digital communication (AgrimagP2)	RS485 communication bus + I/O	
Digital Data logger (AgrimagP2)	Flash memory 131072 records, 15seconds minimal record interval. Saves Date, Time and Total volume	

12. Flowmeter dimensions

	A	B	C	D	E	F
25 mm	100	130	80	25.4	139.7	41.402
50 mm	100	150	82.55	50.8	139.7	51.562
80 mm	100	180	111	76.2	185	64.8

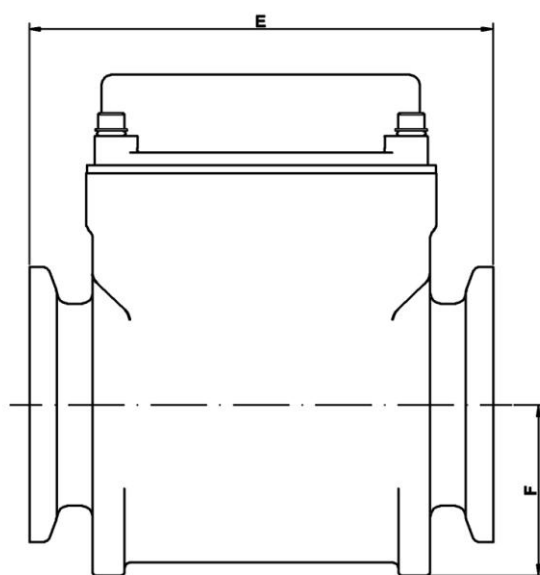
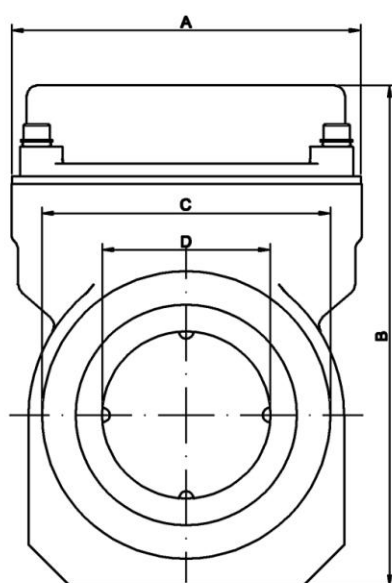

13. Fittings

AGRIMAG, AGRIMAGP, AGRIMAGP2 SIZE		
25 mm		
PIPE CONNECTION	PART NUMBER	DESCRIPTION
Male BSP	M100BSP	1" Manifold x 1" Male BSP
Female NPT	M100050FPT	1" Manifold x 1/2" Female NPT
	M100075FPT	1" Manifold x 1" Female NPT
	M100FPT	1" Manifold x 1.1/4" Female NPT
Male NPT	M100075MPT	1" Manifold x 3/4" Male NPT
	M100MPT	1" Manifold x 1" Male NPT
	M100125MPT	1" Manifold x 1.1/4" Male NPT
Male NPT 316SS	M100MPTSS	1" Manifold x 1" Male NPT SS
Flanged Couplings	M100CPG	1" Manifold x 1" Manifold
Male QDC	M100A	1" Manifold x 1" Male QDC
Hose Barb	M100075BRB	1" Manifold x 3/4" Hose Barb
	M100BRB	1" Manifold x 1" Hose Barb
	M100125BRB	1" Manifold x 1.1/4" Hose Barb
Socket weld 316 SS	M100SWFSS	1" Manifold x 1" Socket weld fitting

50 mm		
PIPE CONNECTION	PART NUMBER	DESCRIPTION
Male BSP	M220BSP	2" Manifold x 2" Male BSP
Female NPT	M220FPT	2" Manifold x 2" Female NPT
Male NPT	M220MPT	2" Manifold x 2" Male NPT
Male NPT 316SS	M220150MPTSS	2" Manifold x 1.1/2" Male NPT SS
	M220MPTSS	2" Manifold x 2" Male NPT SS
Flanged Couplings	M220CPG	2" Manifold x 2" Manifold
	M220CPG6	2" Manifold x 2" Manifold x 6" long
Female QDC	M220D	2" Manifold x 2" Female coupler QDC
Male QDC	M220A	2" Manifold x 2" Male QDC
Hose Barb	M220125BRB	2" Manifold x 1.1/4" Hose Barb
	M220150BRB	2" Manifold x 1.1/2" Hose Barb
	M220BRB	2" Manifold x 2" Hose Barb
Socket weld 316 SS	M220SWFSS	2" Manifold x 2" Socket weld fitting
	M220375SWFSS	2" Manifold x 2" Socket weld Fitting 3.3/4"

80 mm

PIPE CONNECTION	PART NUMBER	DESCRIPTION
Male BSP	M220BSP	2" Manifold x 2" Male BSP
Female NPT	M300FPT	3" Manifold x 3" Female NPT
Male NPT	M300MPT	3" Manifold x 3" Male NPT
Male NPT 316SS	M300220MPTSS	3" Manifold x 2" Male NPT SS
Flanged Couplings	M300MPTSS	3" Manifold x 3" Male NPT SS
	M300CPG	3" Manifold x 3" Manifold x 4" long
Female QDC	M300CPG7	3" Manifold x 3" Manifold x 7" long
Hose Barb	M300A	3" Manifold x 3" Male QDC
	M300220BRB	3" Manifold x 2" Hose Barb
	M300BRB	3" Manifold x 3" Hose Barb
Socket weld 316 SS	M300SWFSS	3" Manifold x 3" Socket weld fitting
	M300375SWFSS	3" Manifold x 3" Socket weld Fitting 3.3/4"

Clamps and gaskets

	PART NUMBER	Size 25mm	PART NUMBER	Size 50mm	PART NUMBER	Size 80mm
Clamp	FC100	Pair	FC220	Pair	FC300	Pair
Gasket	M101G	Pair EPDM	M221G	Pair EPDM	M301G	Pair EPDM
	M100GV	Pair Viton	200GV	Pair Viton	M301GV	Pair Viton

Example of fitting kit

All the fitting kits except the spare calmp pair and spare gasket pair includes:

2 fittings parts + 2 clamps + 2 gaskets.



14. Troubleshooting

14.1. Trouble: non working display

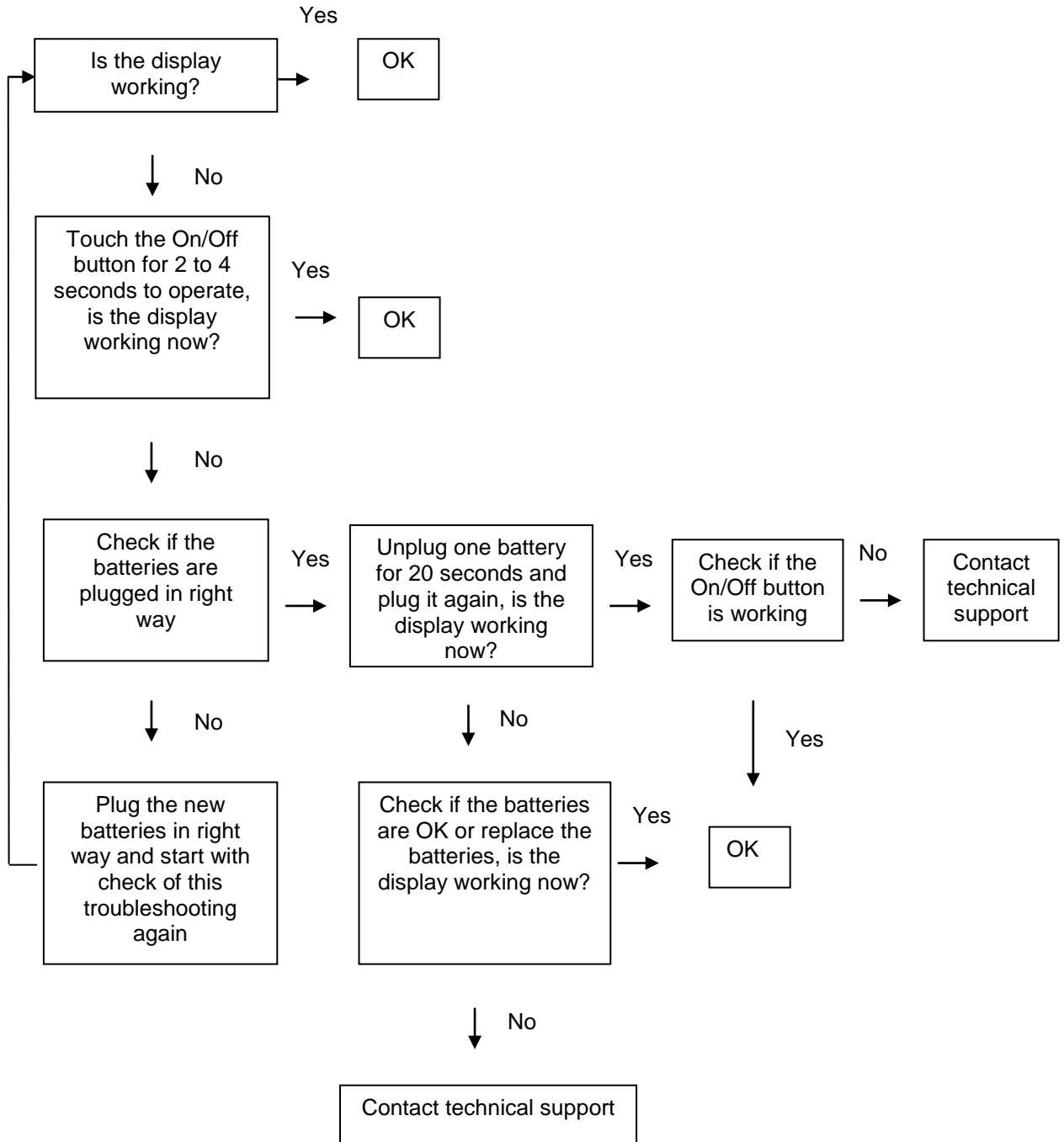

14.2. Trouble: Non stable flow or Empty pipe alarm

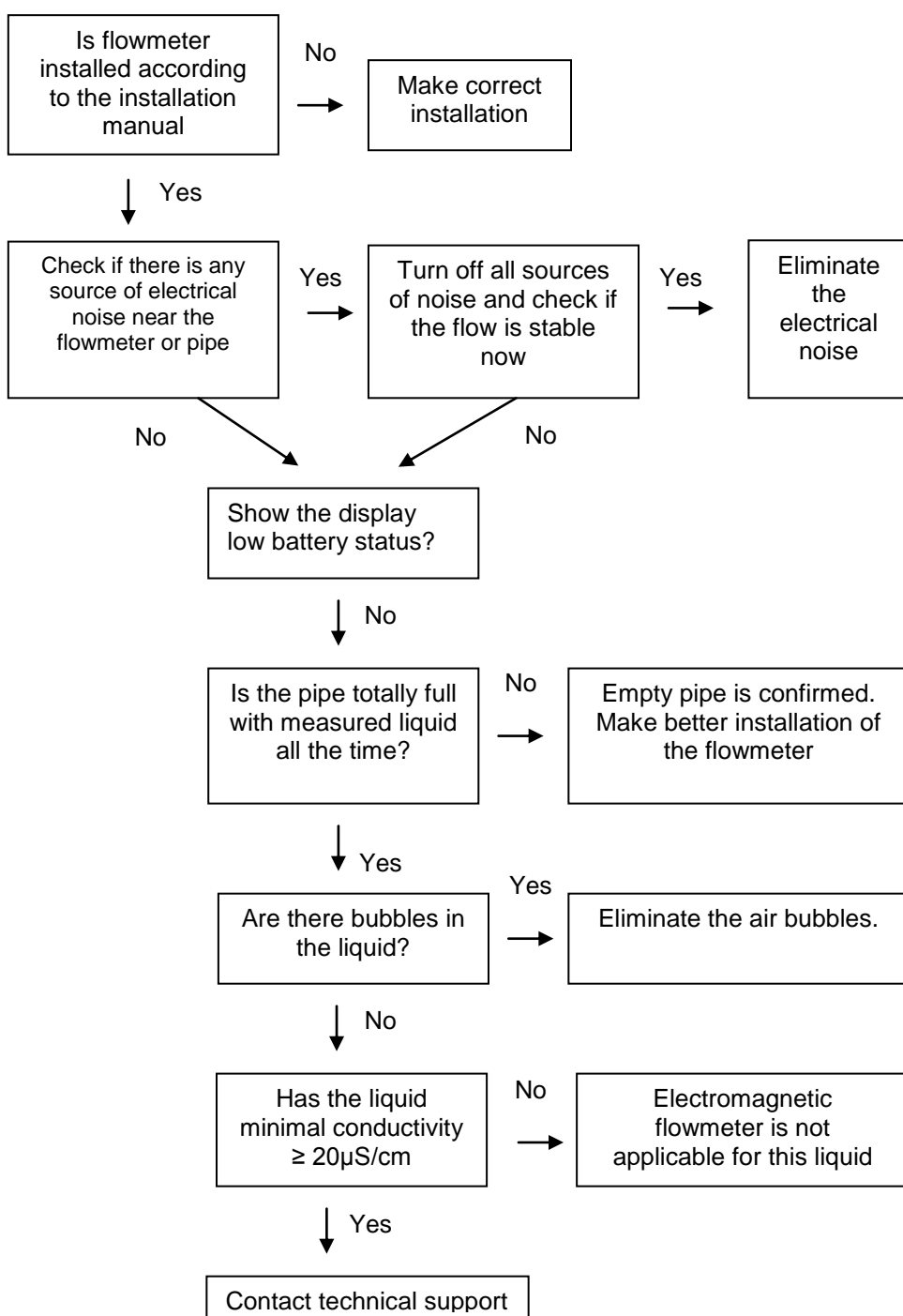
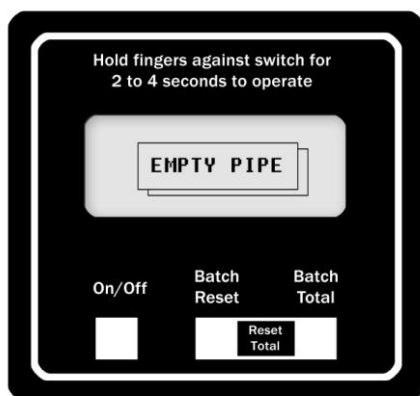

14.3. Trouble: Error overloaded

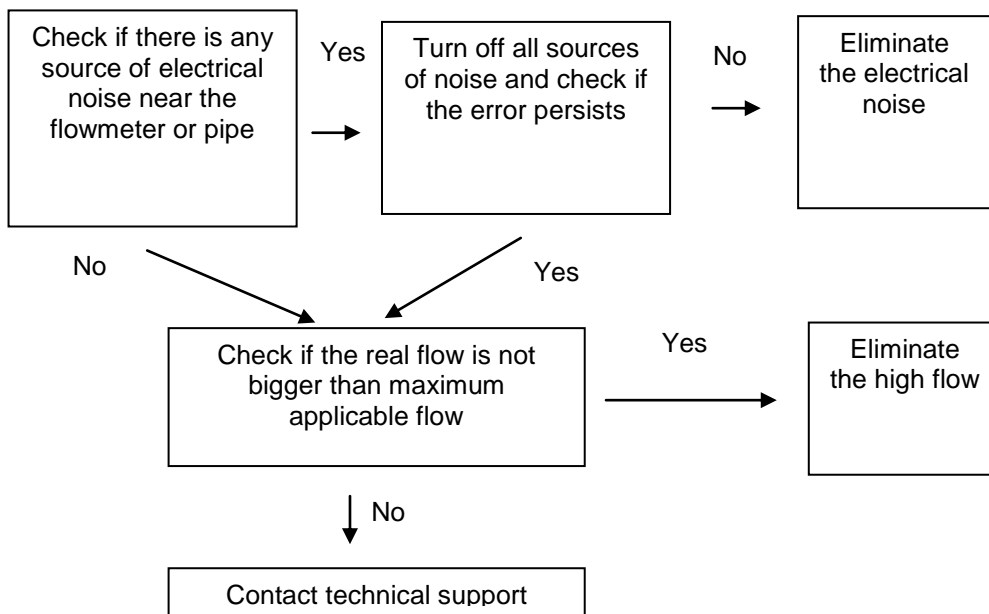
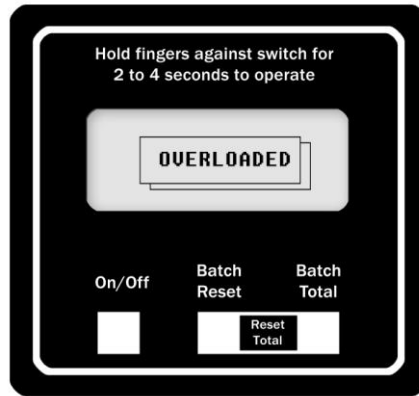

14.4. Trouble: Error excitation

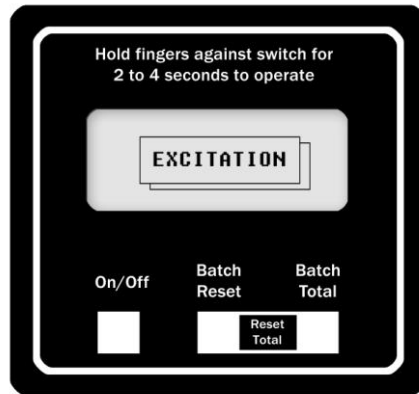

Contact technical support

14.5. Trouble: AD – converter error

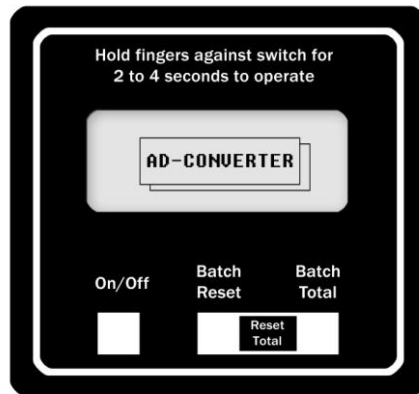

Contact technical support

14.6. Trouble: Low battery error*

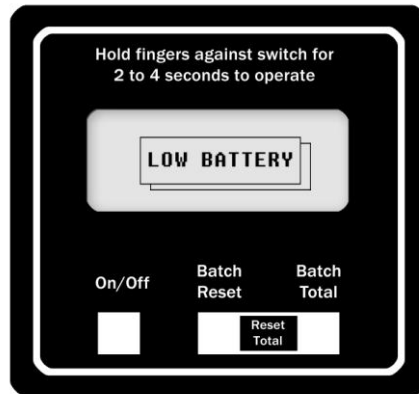

Replace the batteries. Install correctly

*Applies for Agrimag only

15. How to order your Agrimag, AgrimagP, AgrimagP2

Model	Ordering code		Description
Agrimag/AgrimagP/ AgrimagP2	1	2	
			<i>Size</i>
	25		25mm
	50		50mm
	80		80mm
			Connections
		NPT	NPT female
		MAN	Manifold

Example

AgrimagP	25	NPT
----------	----	-----

16. Appendix

16.1. CE requirements

Agrimag, AgrimagP, AgrimagP2 flowmeters are manufactured conforming to CE requirements.



16.2. Warranty

The warranty conditions are covered by Aquamonix Pty Ltd Terms & Conditions of Sale and by Aquamonix Pty Ltd Return Regulations and Warranty Conditions.

16.3. Contact



Technical support: support@aquamonix.com.au

Sales Office: sales@aquamonix.com.au